

REVISIONS			
REV.	DESCRIPTION	DATE	ECN
A	INITIAL RELEASE	8/11/03	
B	UPDATE HOLE SIZES	3/13/12	1494

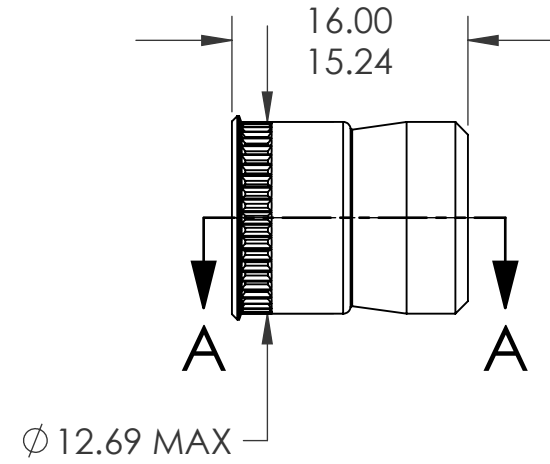

M8X1.25 "OVER SIZE"
NON-GAUGEABLE THREAD

SECTION A-A
SCALE 2 : 1

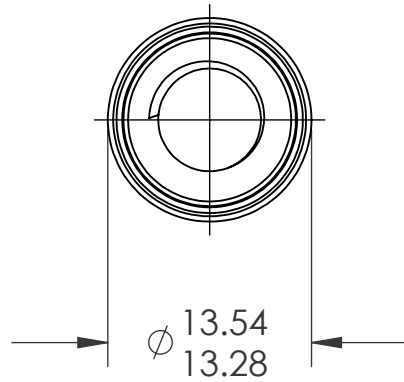
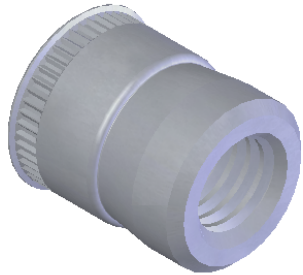
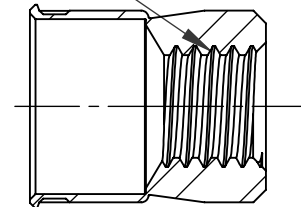

NOTE:

- GRIP RANGE: 0.76 MIN.
- HOLE SIZE:
 - 0.76 - 2.29 MT'L THICK.: 12.70 AFTER ALL APPLIED FINISHES.
 - 2.31 - 3.15 MT'L THICK.: 12.70 AFTER ALL APPLIED FINISHES.
 - 3.17 - 4.72 MT'L THICK.: 13.09 AFTER ALL APPLIED FINISHES.
 - 4.72 - OVER MT'L THICK.: 13.09 AFTER ALL APPLIED FINISHES.
- INSTALLED LENGTH: N/A
- LUBRICATION: NONE
- INSTALLATION TOOL: SSG 803 SPIN SPIN

PROPRIETARY AND CONFIDENTIAL
THIS DRAWING, AND THE INFORMATION CONTAINED HEREIN, ARE THE PROPERTY OF SHEREX AND ARE NOT TO BE USED IN ANY MANNER DETRIMENTAL TO THE INTEREST OF THE COMPANY.
SHEREX SOLUTIONS RESERVES THE RIGHT TO REVISE PART/DRAWING WITHOUT NOTICE.

		UNLESS OTHERWISE SPECIFIED:		NAME	DATE	
		DIMENSIONS ARE IN MILLIMETERS TOLERANCES: ANGULAR: MACH ± 1 BEND ± 1 ONE PLACE DECIMAL ± 0.10 TWO PLACE DECIMAL ± 0.05		DRAWN	JLA	
		INTERPRET GEOMETRIC TOLERANCING PER: ASME Y14.5M-1994		CHECKED		
		MATERIAL		ENG APPR.	JLA	8/11/03
		12L14		MFG APPR.	AJP	8/11/03
		FINISH		Q.A.		
		CADMIUM PER QQ-P-416 TYPE I CLASS 3		COMMENTS:		TITLE: SMALL FLANGE SWAGING
NEXT ASSY	USED ON			E-mail: info@sherex.com www.sherex.com Phone: 866-474-3739 Fax: 716-875-0358		
APPLICATION		DO NOT SCALE DRAWING		SIZE DWG. NO. A CAT2-8125		REV B
				SCALE: 2:1 WEIGHT: .0059 kg		SHEET 1 OF 1